

FKA900**THERMO-COOKERS "CLASSICA"**

mm 900x600xh860

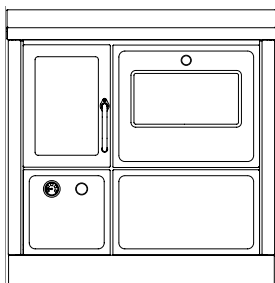
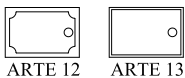
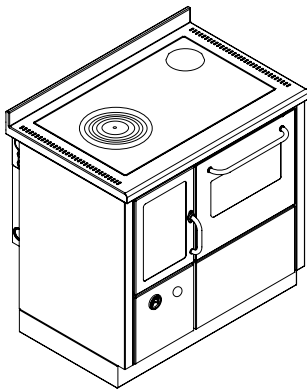

ARTE 11

Available in colors

White, Blue, Green, Grey, Black, Red, Ivory, Rust, Stainless steel

(stainless steel satin-finished)

Version Arte 11,12,13,

White, Blue, Green, Grey, Black, Red, Ivory, Rust

(choice of knobs: nickel-plated, satin-finished, polished brass)

STANDARD EQUIPMENT

- oven of mm. 360x460xh235
- cast-iron hotplate mm 740x450 with cooking rings set
- right or left top flue outlet \varnothing 130 mm
- stainless steel frame of mm 40 (total h860 mm) A1-B1
- rise type A1 mm 60x15
- base h.100 mm. stainless steel

ON DEMAND

- safety thermic exhaust outfitted for close circuits implants
- rear flue outlet, right or left \varnothing 130 mm
- glass-ceramic hotplate (rear flue only)
- external flue air \varnothing 80 mm

OPTIONAL

- front, 2 or 3 side handrail \varnothing 20 mm, Stainless steel or brass
- stainless steel cover
- high performance hotplate

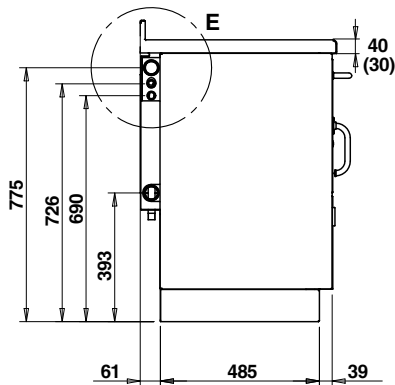

Right flue version. Left flue version is symmetrical

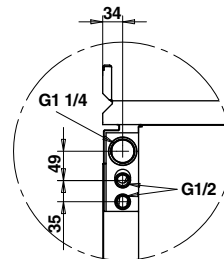
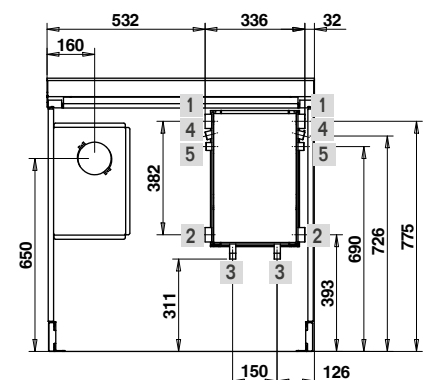
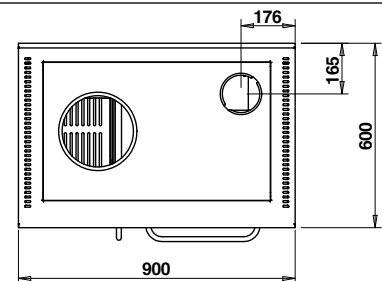
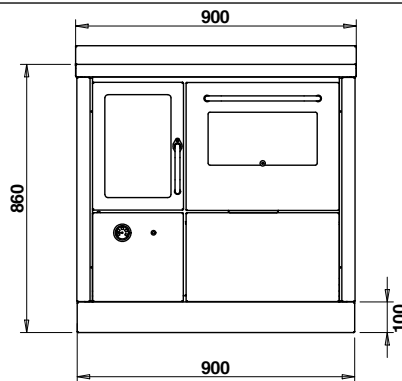

Dettaglio E

- 1 Out connection 1" 1/4 female
- 2 In connection 1" 1/4 female
- 3 Connection for thermal outflow circuit 1/2" male
- 4 Connection for thermal outflow tube 1/2" female
- 5 Available for temperature probe

DATA SHEET

Energy Efficiency Class: A+	Efficiency: 85.4 %
Nominal heat output (max): 12.7 (20) kW	Nominal water heat output (max): 4.6 (14) kW
Mean content of CO to 13% O ₂ : 0.09 %	Average DUST content to 13% O ₂ : 21.1 mg/Nm ³
Maximum operating pressure: 2.0 bar	Boiler capacity: 20 Lt
Hearth dimensions (LxPxH): 22x41x45 cm	Fill opening (LxH): 21x23 cm
Mean flue gas temperature: 228 °C	Flue gas mass flow: 9.9 g/s
Flue depression: 0.12 mbar	Net weight/packaging included: 230/250 kg